

# INSTALLATION INSTRUCTIONS FOR STUCKI® 690-RL RESILIENT SIDE BEARINGS ON LIGHT-BODIED 100- AND 125-TON FREIGHT CARS

## I. INTRODUCTION

The Stucki model 690-RL is a non-metal capped constant contact standard travel side bearing. The 690-RL side bearing\* consists of ① three RB-17 resilient blocks, ② two hardened steel cage end-closures, ③ two 4" x 2" rockers and ④ one 690 side bearing cage. The 690-RL components shown in Figure 1 should not be assembled into any other side bearing housing unless specifically approved by A. Stucki Company.

\*manufactured under one or more of the following patents: us pat 3957318, 4080016, 4090750

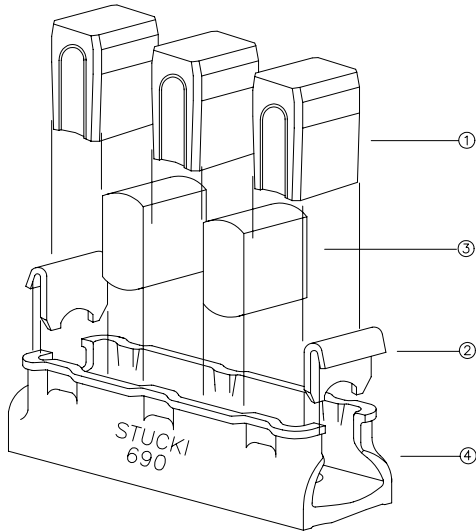

Figure 1. 690-RL Components

The 690-RL side bearing has a nominal preload of 3,600 lbs. The 690-RL is designed for use on cars having body weights (less trucks) between 17,000 and 28,250 pounds.

It should be noted that Stucki manufactures several different resilient side bearing models, all of which use a different and exclusive resilient block design. The resilient blocks (RB-17) used in the 690-RL are not interchangeable with the blocks in any other side bearing model. The distinguishing features of the RB-17 are illustrated in Figure 2. In addition, all blocks are individually marked, as are the shipping cartons.



Figure 2. RB-17 Resilient Block

It is also important to note that the cage end-closure, although having undergone a series of geometry changes since introduced, is interchangeable between all Stucki resilient side bearing models, whether conventional or metal-capped.

Finally, it must be noted that A. Stucki Company does not recommend the application of 690-RL's to torsionally stiff, long truck center length cars having D-3 (2-1/2" travel) truck springs. This includes, but is not necessarily limited to tank cars, boxcars and covered hoppers with truck centers exceeding 36'.

To insure the proper life and performance of the 690-RL resilient side bearing, as well as the operating safety of the freight cars to which they are applied. The following instructions must be carefully adhered to.

## II. ACHIEVING PROPER VERTICAL SET-UP HEIGHT

Vertical space between the car body side bearing wear plate ⑥ (or wedge) and the truck bolster surface to which the side bearing cage is mounted must be 5-1/16" ± 1/16", measured as illustrated in Figure 3.

Note that, although shimming under side bearing cages is not recommended, this may be encountered with some older cars. In such cases, the set-up height measurement must be taken from, or referenced to, the tops of these shims.

Measurement of the side bearing space must always be made with the empty car positioned on reasonably level track (near zero cross-level difference) before installing the resilient blocks or applying any form of solid centerplate lubrication (this is to insure metal-to-metal centerplate contact).

If elastomeric centerplate horizontal liners will be used, they must be in place when set-up height measurements are taken. Also, when such liners are used, A. Stucki Company recommends that the set-up heights be adjusted to 5-1/8" ± 1/16" to allow for compression set of the liner material. Further, it should be noted that the control of truck hunting may be diminished somewhat when low-friction centerplate liners are used, or when centerplates are lubricated excessively.

When body side bearing adjustment is required to obtain the specified set-up heights, it is acceptable to average the measurements for the two side bearings at each end of a car. The sum of both measurements may thus be as low as 10", or as high as 10-1/4". However, in no case may an individual space be under 5".

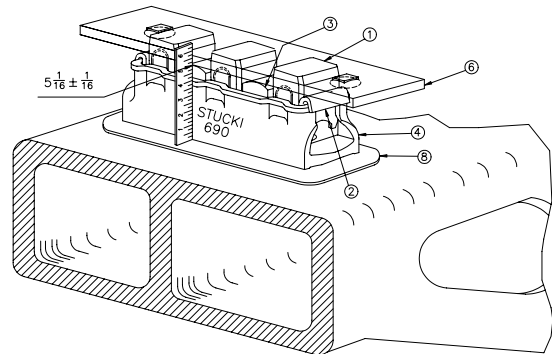

Figure 3. Set-Up Height Measurement

## III. CAR BODY SIDE BEARING WEAR PLATE

Body side bearing wear plate ⑥ (or wedge) must conform to AAR Standard S-235-83. Wear surface must be smooth. Any weld spatter, heavy rust, or surface projections must be removed by grinding. Fastener heads ⑦ must be flush or recessed with the wear plate surface. Fasteners must be securely tightened.

Plates or wedges with surface variations between fastener holes (roller impressions, convexity or concavity) greater than 1/8" or greater than 1/16" over any 4" space, must be replaced. Wear plate surface must be reasonably parallel to the side bearing mounting surface of the truck

bolster. Variation should not exceed 1/16" across width, or 1/8" end-to-end.

Body wear plates must be of sufficient length and width to maintain engagement with the resilient blocks when the car negotiates the tightest curves for which it is designed. For cars having a 150' minimum radius curve negotiation requirement, the following table provides a guide for the minimum wear plate length.

Truck Center Length	Min. Wear Plate Length
25' or less	14"
25'-1" to 35'	16"
35'-1" to 40'	17"
40'-1" to 45'	18"
45'-1" to 50'	19"
Over 50'	21"

Cars having a truck center length greater than 37' must be equipped with 5" wide wear plates.

Wedge type wear plates having fastener hole centers under 15-1/2" should not be used on cars having a truck center length greater than 46'.

When first applying new resilient blocks, a thin coating of lubricant (#2 lithium grease or equivalent) must be applied to the entire lower surface of the body side bearing wear plate, or wedge. Excessive lubricant should be avoided. Lubricant should never be applied before running car through grit-blast facility. Never use asphaltic or molybdenum disulfide type lubricants. Lubrication is required to reduce wear plate friction only during initial break-in, or conditioning period. After a short period of service, the lubricant is dissipated. The resilient blocks, then contacting a relatively unlubricated, but somewhat polished surface, will function to give maximum hunting control. The body side bearings should never be re-lubricated in service, except in cases where new wear plates are installed.

#### IV. TRUCK SIDE BEARING

The 690 side bearing cage ④ (see Figure 3) must be free of flaws or cracks and must be securely fastened to the truck bolster. Please refer to A Stucki Company's roller side bearing installation instructions for cage fastener recommendations.

The cage fastener heads ⑤ must be reasonably flush with the contour of the bottom of the cage. The holes in the RB17 blocks are not designed to accommodate protruding fasteners heads.

The internal length of the cage (between end gibs) must be no less than 11-5/8". Cages not meeting this requirement should be replaced.

The inside edges of the end gibs must be free of upset metal that could prevent the end-closure ② from fitting flush against the inside faces

#### V. RESILIENT BLOCKS

The RB-17 resilient blocks when compressed by the car body to the nominal 5-1/16" set-up height will provide, after an initial break-in relaxation period, approximately 3,600 pounds of vertical pre-load. The initial relaxation period will be about 12 to 24 hours if the temperature of the resilient blocks is above 50°F. During this time the car body centerplate may not be in contact with the truck bolster, since side bearings with the new blocks installed can initially support as much as 10,000 pounds per bearing. However, with proper body side bearing lubrication initial wear plate friction is very low, and the car should experience no difficulty moving through curves.

Until initial relaxation of pre-load has occurred, the vertical space at a side bearing will probably be greater than as originally set up. It will gradually approach the anticipated dimension. At temperatures below 50°F, this may require more than 24 hours. For this reason, blocks being installed in a cold environment should be stored at near room temperature for at least 24 hours prior to installation.

If solid lubricants have been applied to the centerplate, the anticipated side bearing height may not be realized until after the car has been moved for some distance, as some solid lubricants are capable of supporting considerable vertical load.

The resilient blocks must not be exposed to temperatures greater than 200°F, or 175°F for extended periods of time, if cages have been riveted, welded, or otherwise heated for any reason, the resilient

blocks should not be installed until the cage and fasteners have cooled to a touch-safe temperature.

Whenever a car having 690-RL's is raised from the trucks and the blocks are removed, measurement of their free height will reveal them to be somewhat shorter than a new block of the same design. During its normal life, the RB-17 block can take as much as 1/4" permanent set, and still function to give adequate hunting control. Stucki Service Bulletin RSB8904 gives guidelines for block replacement due to age or to minimum free height requirements.

#### VI. INSTALLATION OF COMPONENTS INTO CAGE (see Figure 1)

1. Insert the end closures ② into place
2. Position the three resilient blocks ① and two steel rocker elements ③ as indicated in Figure 1.

All elements should fit into place easily. If elements must be forced into position, disassemble and review Section IV: Truck Side Bearing.

Note that in service the rockers may not always seat on the cage bottom. The total free space above and below the rockers will generally be equivalent to conventional side bearing clearance, and depending on the free space below the rockers, the visible clearance between rockers and wear plate will vary. Rocker to wear plate clearance must not be used as a set-up criterion. The side bearing space set up described in Section II: "Achieving Proper Vertical Set-Up Height" must be followed.

After the resilient side bearings have been assembled and the car body has been lowered onto the trucks, a visual check should be made of the relative lateral position of the body side bearing wear plates or wedge with respect to the resilient blocks. This is particularly important in the case of 4" wide wedges, the lateral position of which varies with the amount of shim applied. As indicated in Figure 4, there should be a minimum plate or wedge "overhang" of 1/2" toward the center of the car and a minimum of 1/4" toward the outside. A 4" wide plate or wedge not meeting this requirement should be replaced by one 5" wide.

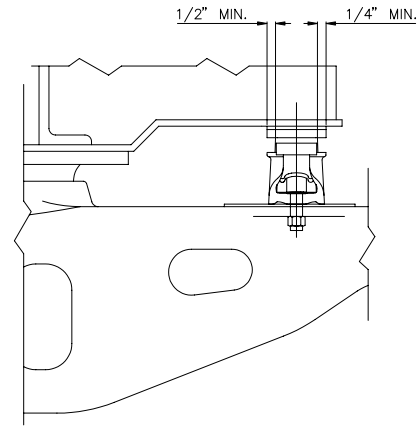

Figure 4. Minimum Plate or Wedge Overhang

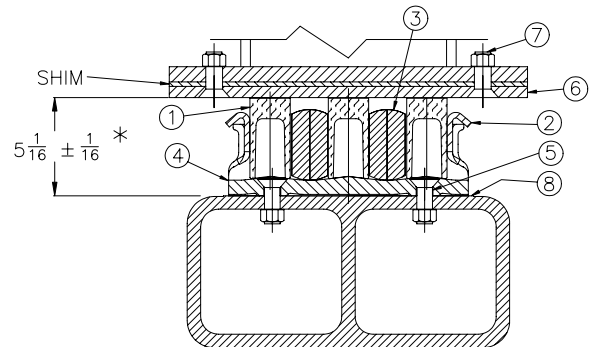

Figure 5. 690-RL Side Bearing Arrangement