

INSTALLATION INSTRUCTIONS FOR STUCKI® DUAL ACTION METAL-CAPPED RESILIENT SIDE BEARINGS, MODELS ISB-8, ISB-10 AND ISB-12

I. SPECIFICATIONS AND MODEL SELECTION

A. Stucki Company manufactures three dual action metal-capped resilient side bearing models designed to control truck hunting of freight cars having conventional 3-piece trucks. The primary difference between the models is the preload compression force provided by the resilient elements at the nominal 5-1/16" operating height, and the non-interchangeability features incorporated to meet requirements of AAR Specification M-948. Selection of the appropriate model is based upon the empty weight of the car body (less trucks). Specification M-948 limits total side bearing preload to no greater than 85% of the empty car body weight. The following table provides a guide for proper model selection for stand-alone cars (consult A. Stucki Company for selection for articulated cars).

METAL-CAPPED ISB MODEL	NOMINAL PRELOAD* AT 5-1/16"	ALLOWABLE EMPTY CAR BODY WT.	APPROX. LT.WT. WITH 70-T. TRUCKS	APPROX. LT.WT. WITH 100-T. TRUCKS
ISB-8	3000#	14,100# - 21,199#	31,000# - 37,999#	35,000# - 41,999#
ISB-10	4500#	21,200# - 28,199#	38,000# - 44,999#	42,000# - 48,999#
ISB-12	5400#	28,200# or GREATER	45,000# or GREATER	49,000# or GREATER

*AFTER NORMAL BREAK-IN RELAXATION HAS OCCURRED.

II. IDENTIFICATION AND DESCRIPTION OF COMPONENTS

All Stucki metal-capped ISB models are similar in design. Each consists of a metal cap element in the form of a double wedge that rests upon a pair of sloped-top resilient polyurethane blocks. Adjacent to the resilient blocks, sitting in a metal cradle, is a 3" diameter hardened steel roller that serves as a compression travel limit. These components are contained in a rolled steel cage. The end of the cage adjacent the resilient blocks is fitted with a hardened steel end-closure to properly buttress and contain the resilient blocks.

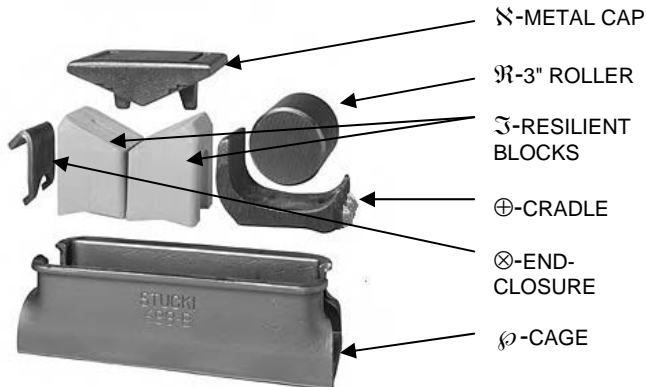

Figure 1. Stucki Dual Action Metal-Capped ISB Components

The cages for the ISB-8 and ISB-10 bear the basic model designation stamped onto one side. The ISB-12 utilizes a standard Stucki 688-B cage. The resilient blocks and metal caps are imprinted with their appropriate and matching design number. The proper, and only, block and cap design to be used in each model is:

METAL CAPPED ISB MODEL	METAL CAP DESIGN	RESILIENT BLOCK DESIGN
ISB-8	RB-24 CAP	RB-24
ISB-10	RB-34 CAP	RB-34
ISB-12	RB-27 CAP	RB-27

All models use a common design 3" diameter X 3" long steel roller and 5/16" thick cage end-closure (the latter being identical for all Stucki RSBs, whether conventional or metal-capped).

Model ISB-12 utilizes a standard 688-B double roller side bearing cage. This allows easy retrofit of the ISB-12 to 100 and 125-ton cars already equipped with such cages. The cages for models ISB-8 and ISB-10 incorporate depressions in the upper sidewalls that act as rejection features to preclude the insertion of resilient block designs of higher nominal preload than those standard for the model. The ISB-8 cage has four such depressions, two in each sidewall at the block locations. The ISB-10 cage has a single depression in each wall, diagonally opposed. The corresponding resilient blocks conform to the cage wall conditions. The RB-27 block is flat on both sides. The RB-24 block is channeled on both sides to allow fitting between the reduced width at the cage wall depressions. The RB-34 block is channeled on one side only in like fashion. Figure 2 illustrates the distinguishing features of each block.

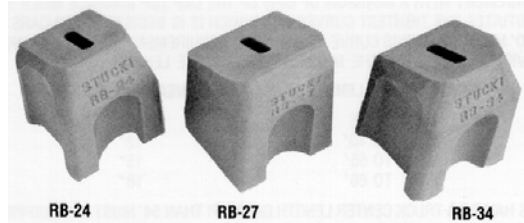

Figure 2. Metal-Capped RSB Resilient Block Designs

It is important to note that A. Stucki Company does not recommend the application of metal-capped resilient side bearings to torsionally stiff, long truck center length cars having D-3 (2-1/2" travel) truck springs. This includes, but is not necessarily limited to tank cars, boxcars, and covered hoppers with truck centers exceeding 38'.

III. INSTALLATION PROCEDURES To insure the proper life and performance of Stucki resilient side bearings, as well as the operating safety of the freight cars to which they are applied, the following instructions must be carefully adhered to:

1. Achieving Proper Vertical Setup Height

Vertical space between the car body side bearing wear plate (or wedge) and the truck bolster surface to which the side bearing cage is mounted must be 5-1/16", +/-1/16", measured as shown in Figure 3.

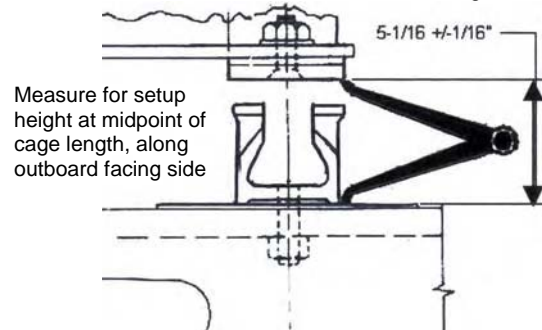

Figure 3. Measurement for Setup Height

Note that, although shimming under side bearing cages is not an acceptable procedure, this may be encountered with some older cars. In such cases the setup height measurement must be made from, or referenced to, the top of the shims.

Measurement of side bearing space must always be made with the empty car positioned on reasonably level track and before installing the resilient blocks in the cages or applying any form of solid centerplate lubrication (this is to insure metal-to-metal centerplate contact).

If any type of semi-permanent elastomeric centerplate horizontal liners are to be used, these must be in place when setup height measurement is made. Also, in such cases, A. Stucki Company recommends that setup heights be adjusted to 5-1/8" +/-1/16" to allow for early "seating-

in" and compression set of the liner material. Further, it should be noted that **control of truck hunting may be diminished somewhat when low friction centerplate liners are used**, or when centerplates are lubricated excessively.

In the case of retrofit applications, when body side bearing shim adjustment is required to obtain the specified setup height, it is acceptable to average the measurements for the two side bearings at a given end of the car. The sum of both measurements may be as low as 10" or as high as 10-1/4". **No individual space, however, should be under 5".**

2. Car Body Side Bearing Wear Plates

Body side bearing wear plates (or wedges) for use with Stucki side bearings of any style **must conform to AAR Standard S-235**. Surfaces must be smooth. Any weld spatter, heavy rust, or surface projections must be removed by grinding. **Fastener heads must be flush with, or recessed into, the wear plate surface.** Fasteners must be properly tightened and secured.

Plates and wedges with surface variations greater than 1/8" between fastener holes (roller impressions, convexity, or concavity), or greater than 1/16" over any 4" space, must be replaced. Wear plate surface must be reasonably parallel to the side bearing mounting surface of the truck bolster. Variation should not exceed 1/16" across width or 1/8" end-to-end.

Body wear plates must be of sufficient length and width to maintain engagement with a minimum of 60% of the cap top surface when the car negotiates the shortest radius curves for which it is designed. For cars having a 150' minimum radius curve negotiation requirement, the following table provides a guide for the minimum wear plate length:

TRUCK CENTER LENGTH	MIN. WEAR PLATE LENGTH
28' OR LESS	10"
28'-1" TO 40'	12"
40'-1" TO 55'	15"
55'-1" TO 66'	18"

Cars of truck center length greater than 48' must be equipped with 5" wide wear plates.

3. Truck Side Bearing

The side bearing cage must be free of flaws or cracks and **must be securely fastened to the truck bolster**. Refer to A. Stucki Company's *Installation Instructions for Roller Side Bearings* for cage fastener recommendations. Note that Stucki recommends, on stand-alone, single unit cars, that the **ISB models be installed such that the rollers are diagonally opposed across the truck bolster**. ISB-8 and ISB-10 cages should be orientated with the resilient block indents always to the installers same hand as he faces the near side frame.

The heads of the cage fasteners must not interfere with the seating of the resilient blocks to the cage floor.

The new nominal diameter of the steel roller is 3". **This is the only size roller that may be used in the side bearing models covered by these instructions.** Maximum allowable wear is 1/16". Rollers under 2-15/16" diameter must be replaced.

4. Resilient Blocks

New resilient blocks, when **initially** compressed by the car body to the nominal 5-1/16" setup height, will support loads greater than the nominal design compression preload values shown in the table in Paragraph I (above). The actual loads borne by the side bearings will diminish to approximately the design preload level **after an initial break-in relaxation period, which will normally include a short time in revenue service.** Depending on the ambient temperature, the temperature of the resilient blocks when installed, and the weight of the car body, the body centerplate may not achieve metal-to-metal contact until some portion of the preload relaxation has occurred. This may require as much as 24 hours. The initial relaxation period can be minimized during periods of low temperatures (below 50°F) **by storing the resilient blocks at room temperature for at least 24 hours prior to installation.** During the short period while the centerplates may not be contacting, the lubrication of the side bearing cap as specified in Paragraph 5.E (below) insures the car will experience no difficulty negotiating curves.

If solid lubricant discs or patties have been applied to centerplates, the anticipated side bearing heights may not be realized until after car has

been moved for some distance, as some solid lubricants are capable of supporting considerable loads statically.

Resilient blocks must never be exposed to temperatures greater than 200°F, or 175°F for extended periods. If cages have been riveted, welded, or otherwise heated for any reason, the resilient blocks should not be installed until cage and fasteners have cooled to touch-safe temperatures.

When a car having Stucki RSBs is raised from the trucks and the resilient blocks are removed, measurement of their free heights will reveal them to be somewhat shorter than new blocks of the same design. During normal block life, they can take as much as 1/4" compression set (depending on block design) and still function to provide adequate hunting control. The *Stucki Yard and Shop Inspection Pocket Guide* includes tables that provide a guide for the replacement of blocks on the basis of time/mileage or free height measurement.

5. Installation of Components Into Cage (see Figure 1)

- Insert end-closure⊗ into place on end of cage ρ where resilient blocks are to be located. ISB-8 and ISB-10 cages should be installed so that resilient blocks are diagonally opposed from one end of bolster to the other. In ISB-12 case, place end-closures on cage ends diagonally opposed across bolster.
- Position cradle⊕ in place at opposite end of cage, tall leg to the center of the cage (to properly buttress resilient blocks).
- Position resilient blocks⊃ between cradle and end-closure, sloped tops facing toward each other.
- Drop the 3" diameter roller⊖ in place in the cradle, **cylindrical surface contacting cradle floor.**
- Place metal cap⊘ onto the resilient blocks, being certain that the fins on the underside of the cap engage into the slots on the sloped faces of the blocks. Seat the cap into the blocks as far as possible manually. The cap will be seated flush to the blocks when the car body is lowered onto the trucks.
- When first installing new metal-capped resilient side bearings, after installing all components into cages, and prior to lowering the car body onto the trucks, **installer must apply a "dab" (approx. 1-1/2" diameter) of lubrication to the center of the cap top surface (see Figure 4) for break-in purposes.** Recommended lubricant is any lithium based grease. **Do not use any lubricant containing graphite or molybdenum disulphide (MOLY).** Side bearings should never be relubricated in service except in cases where resilient blocks and body side bearing wear plates are being renewed simultaneously.



Figure 4. Lubrication of Metal Cap

After the car body has been lowered onto the trucks, a visual check should be made of the relative lateral position of the body side bearing wear plates with respect to the side bearing metal caps. This is particularly important in the case of 4" wide wedges, the lateral position of which varies with the amount of shim applied. There should be a minimum "overhang" of 1/4" to the inside of the car body (toward the centerplate) and 1/8" to the outside. 4" wide plates or wedges not meeting this requirement should be replaced with the 5" wide style.

A. Stucki Company
2600 Neville Road
Pittsburgh, Pennsylvania 15225
Phone: 412-771-7300
Fax: 412-771-7308
www.stucki.com