

# INSTALLATION INSTRUCTIONS FOR STUCKI EXTENDED TRAVEL SHEAR SIDE BEARINGS (SSB®)

The Stucki Shear Side Bearing utilizes an elastomeric material in shear, rather than compression, to provide the constant contact preload force. Stucki Shear Side Bearings (SSB®) are approved for interchange service under the requirements of AAR Specification M-948. They are available in three different preload models, 4000, 5000, and 6000 lb. The design allows 5/8" of travel, meeting the requirements for extended (long) travel side bearings.

The Stucki Shear Side Bearing consists of a metal cage and a shear element with integral wear cap (cap assembly). The cage is designed for fastening to the truck bolster using two threaded fasteners at the standard 8-1/2" spacing. The cages are identified as either 4000, 5000, or 6000 pound preload models by means of a notch system and raised lettering.

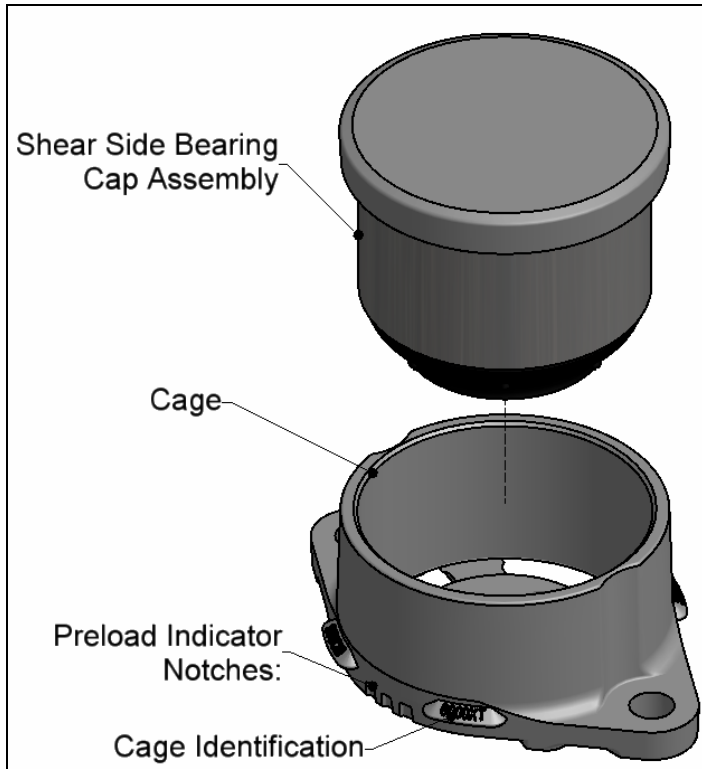

**Figure 1. SSB Side Bearing**

It is useful to note that the SSB cages are the same cage models furnished for the Stucki Column Side Bearing (CSB®). It is also important to note that the features that determine preload and travel are built into the cage design. This satisfies the AAR M-948 requirements for non-interchangeability. **Only the SSB Cap Assembly should be used with the SSB Side Bearing.** Do not use any other elastomer or cap assembly.

## MODEL SELECTION

The Stucki Shear Bearing is available in three models:

SSB-4000XT	4,000# Preload, Extended Travel	1 Notch
SSB-5000XT	5,000# Preload, Extended Travel	2 Notches
SSB-6000XT	6,000# Preload, Extended Travel	3 Notches

AAR specifications require that constant contact side bearings support no more than 85% of the static, empty car body weight (less trucks) at the nominal new preload level. Thus, the minimum acceptable car body weights to which these side bearings can be installed are:

SSB-4000XT	19,765 pounds
SSB-5000XT	24,000 pounds
SSB-6000XT	28,235 pounds

There are no maximum weight limits.

## INSTALLATION REQUIREMENTS AND PROCEDURES

### 1. BODY SIDE BEARING REQUIREMENTS

**New Car Construction:** Body side bearing wear plates must conform to AAR Standard S-235. Fasteners must be of the countersunk head type. Heads must be flush with, or recessed from the wearing surface of the wear plates so there is no interference with the side bearing caps. Body side bearing wear plates (or wedges) should be 5" wide for all stand-alone car types. Minimum lengths should be selected on the basis of the truck center length (centerplate-to-centerplate) for the subject cars from the following chart:

Truck Center Length	Minimum Length Body Side Bearing
28' or less	10"
28'-1" to 48'	14"
48'-1" to 65'	16"
65'-1" or greater	18"

This chart is based upon the AAR requirement for minimum radius curve negotiability of 150'. For cars restricted to larger minimum radius curves, consult Stucki for assistance in determining minimum wear plate requirements. Articulated car designs will have different requirements, dependent upon the arrangement of the side bearings on the shared trucks. Thus, the selection of body side bearing size for multi-unit cars must be based upon design layouts produced by the car designer/builder. A. Stucki Company will furnish the appropriate "footprint" and minimum engagement requirement for the SSBs on request.

**Retrofit Installation:** Existing body side bearings meeting the required minimum length specified by the chart above can be retained for use with the SSBs provided they meet the following additional requirements:

- Existing 4" wide body side bearings are acceptable for cars having a truck center length no greater than 64'.
- Must conform to AAR hardness standards (BHN 277-341).
- Must be in serviceable condition, reasonably flat and smooth, free of rust pitting, weld spatter, or other surface projections, and having no wear depressions greater than 1/16" over any 4" length.
- Must be parallel to truck side bearing mounting surface to within 1/16" across width and 1/8" end-to-end.
- Fastener heads must meet requirements specified above for new cars and must be tight and properly secured.

**Lubrication:** Following installation of the side bearing cap assemblies and prior to lowering the car body onto the trucks, installer must apply lubrication to the side bearing caps. Recommended lubricant is any lithium-based grease. Do not apply lubricants containing graphite or molybdenum disulphide. Lubricant should be applied as a “dab” approximately 1-1/2” to 2” in diameter to the center area of the wear cap. This is a one-time only requirement – no further lubrication of the wear caps or body side bearings is necessary in service except in repair situations when both the side bearing wear cap and body side bearing wear plate are being renewed simultaneously.

**Level Track Requirements:** Installation of side bearings requires that the measurements taken to determine side bearing setup heights be performed with the car setting such that both trucks are positioned on reasonably level track. If track is out of level across gage by more than 3/16”, proper side bearing setup heights may not be achieved, and performance of the side bearing as well as operation of the car may be adversely affected. Installation, therefore, may require the creation of level truck spotting positions by shimming track.

### **SSB Cap Assembly Preparation for Cold Weather**

**Installation:** To ensure mating of car body and truck center plates reasonably soon following final assembly, it is helpful to store the cap assemblies in an area where temperature is above 50°F for about 24 hours prior to their installation.

## **2. INSTALLATION OF SSB CAGES**

SSB cages may be installed prior to or following the measurement for setup height procedures (outlined in #3 following). This can be done to best suit the installer’s production line procedures. If cages are installed prior to grit blast, it is advisable to mask cages to prevent grit from getting inside.

Cages are fastened to the truck bolster (or alternative truck side bearing mounting surface) using two 7/8-9 AUDITORX® dome head Camrail® bolts (7/8-9 TORX® pan head Camrail® bolts or 7/8-9 socket head cap screws grade 5 or better also acceptable). 3-1/4” length is generally suitable for standard truck bolsters, but installer should choose length to suit application. Bolts are applied heads up through cages, nuts inside bolster. If non-breakaway head bolts are used, they must be torqued in accordance with the fastener manufacturer’s specification to yield a clamping force between 20,000 and 30,000 pounds (375-400 ft-lbs dry). Nuts should be of the self-locking type.

## **3. MEASUREMENT TO ACHIEVE PRESCRIBED SETUP HEIGHT**

Obtaining the proper setup height (side bearing height at static level condition) is important to ensure proper performance of the side bearings and safe operation of the car. Car must be positioned on track meeting the requirements discussed in *Level Track Requirements* above, with both centerplates in contact with the truck bolster bowls. Solid centerplate lube patties or discs must not be in place at this time. Centerplate wear liners (metal or plastic), however, must be installed before measuring for setup height. Cap assemblies must not yet be installed in the side bearing cages. The vertical space between the truck bolster (mounting surface for the cage) and the underside, or wearing surface of the body side bearing, must be measured

and recorded at each location (see Figure 2). Measurements should be taken as close to the midpoint of side bearing as possible, and should be taken both sides of center. If the two measurements differ by more than 1/16”, the average of both should be the recorded height from which shim adjustment will be calculated. From each measurement, installer must determine what thickness of body side bearing shim must be added or removed to yield the specified setup height of 5-1/16”, +/- 1/16”. Note that, if nonmetallic centerbowl liners are being used, these must be in place when the measurements for setup heights are taken, and Stucki recommends setting the side bearings to 1/16” higher height (to 5-1/8”, +/- 1/16”) to accommodate future compression set of the liners. Note also that the standard specified setup height applies to all single unit, or stand-alone cars, all drawbar connected cars, and all end-trucks of articulated multi-unit cars. Setup heights for side bearings applied to intermediate trucks of articulated cars may be different based upon customer or car builder requirements.

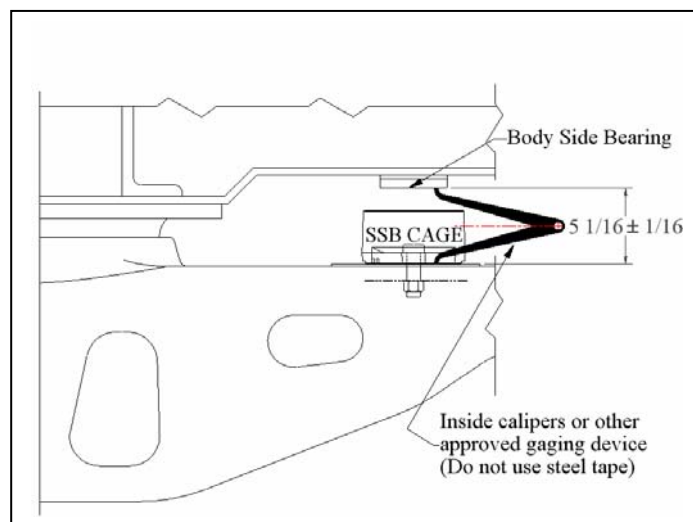

**Figure 2. Setup Height Measurement**

## **4. INSTALLATION OF CAP ASSEMBLIES INTO CAGES**

After all body side bearing shim adjustments have been completed, the cap assemblies can be inserted into the cages to complete the installation. If cars have been run through grit blast on trucks with SSB cages installed, insides of cages must be thoroughly cleaned. Cap assemblies are inserted into the cages as illustrated in Figure 1. Centerplate solid lube discs may now be installed. The car body can then be lowered onto the trucks. New cap assemblies will generally hold the body from flush centerplate contact for a short period, as will solid centerplate lube discs. The time required for the elastomer preload to relax sufficiently to allow the centerplates to contact will be dependent upon the car body weight and the ambient temperature, but will normally not exceed 24 hours. The applied lubrication of the caps of the SSB side bearings allows the cars to be moved through curves without problem during this period. It is also important to note that, for the same reason, it is normally not valid to recheck the side bearing setup heights until at least 24 hours after the elements have been installed.