

# STUCKI RFE-41 RESILIENT FRICTION ELEMENT INSTALLATION INSTRUCTIONS

The Stucki RFE-41 resilient friction element is a column friction snubbing assembly that replaces the Standard Car Truck Company 834-C cast iron friction wedges for 6X11, 6-1/2X12, and 7X12 Barber S-2-HD freight car trucks.

The purpose of the RFE-41 is to reduce the wear that normally occurs on the slope surfaces and sidewalls of the friction wedge pockets in the truck bolster. Friction snubbing forces are the same as that of the S-2-HD system, which the RFE-41 replaces.

## I. NOMENCLATURE AND PARTS DESCRIPTION

The RFE-41 assembly (Fig. 1) consists of an austempered ductile iron wedge element and a resilient urethane pad affixed to the sloped face of the wedge. The two pieces lock together by means of an interlocking "waffle" arrangement at the interface and an interlocking post on the pad which is retained by a tapered hole on the sloped face of the wedge. Along each edge of the vertical (or wearing) face of the wedge are witness grooves to indicate the allowable wear limits.

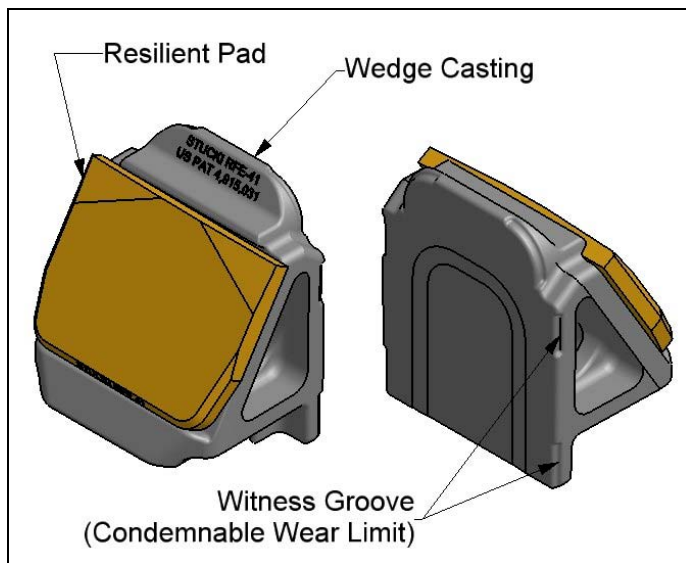

Figure 1

Other parts of the RFE-41 system include two load carrying springs and a hardened column guide wear plate attached to the side frame column. These components are identical to the side coil springs B353 and B354, and column wear plates used in the conventional (all-metal) variable column friction S-2-HD system. In the case of retrofit applications, side springs and column wear plates need not be replaced if in satisfactory condition.

## II. INSTALLATION INSTRUCTIONS

Instructions A, B, and C apply generally to retrofit applications. For new car applications, proceed with Instruction D.

### A. TRUCK BOLSTER PREPARATION

Although no bolster modification is required for RFE-41 installation, it is essential that wedge pocket conditions be inspected for compliance with the following requirements.

### 1. POCKET SLOPE SURFACE WEAR

If a bolster pocket slope exhibits more than 1/8" wear (Fig. 2) when using Barber No. 7 or SK-1689-7 or SK-1689-9 bolster pocket slope gage, the surface must be restored either by rebuilding with weld or by addition of a 1/4" thick slope wear plate, in accordance with conventional practice. A chamfer should be applied to the top lip of the wear plate to avoid fraying the top of the pad.

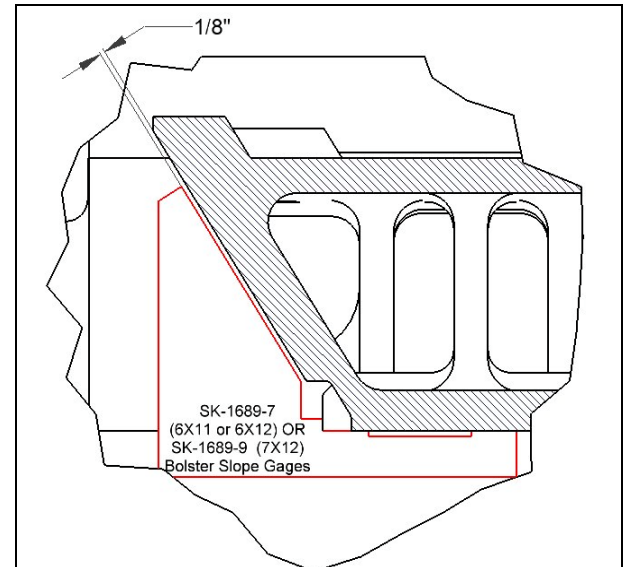

Figure 2

If the slope surface has been rebuilt, the welded area should be ground smooth and flat. This includes removal of weld spatter in the corners and on the sidewalls within 3/4" of corners (see Fig. 3).

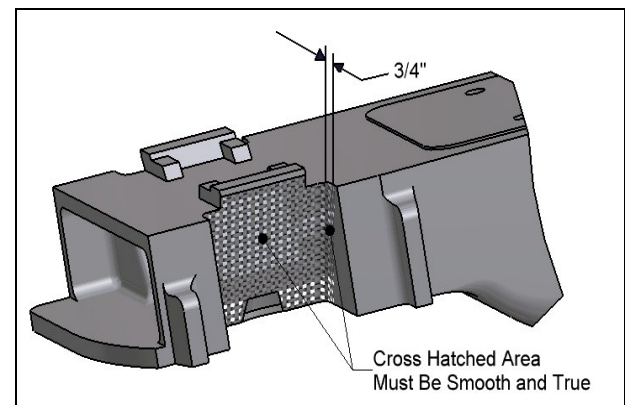

Figure 3

If new slope surface wear plates are applied, all welds, including any center plug-welds, must be ground flush with the wear plate surface. If pocket slopes have previously been fitted with wear plates, they should be inspected and replaced, if necessary, in accordance with AAR interchange Rule 47.

**IMPORTANT:** In all cases, the bolster surfaces that will be in contact with the urethane pads of the RFE-41 wedges must be reasonably smooth and free of projections that may gouge the urethane pad surface. In no case should the RFE-41s be

installed unless rebuilt bolster surfaces have been ground smooth as noted above. Bolster pocket slopes must not be lubricated.

## 2. POCKET SIDEWALL WEAR

In most cases the outboard vertical side wall of the wedge pocket in the truck bolster wears more rapidly than the inboard sidewall. If the pocket width has increased to greater than 7-1/16", the outside sidewall should be restored to the "as new" condition by rebuilding with weld in accordance with conventional practice. Only the area within 3/4" of the slope surface corners need be ground smooth (see Fig. 3).

## B. INSPECTION OF FRICTION WEDGE SPRINGS

1. If existing side coil springs are to be re-applied with the RFE-41 assembly, they should be checked for sufficient free height to insure proper loading of the wedges. Minimum acceptable free heights are 10-13/16" for B353 outer side coil, and 11-1/8" for B354 inner side coil.
2. When RFE-41 applications are made to new cars, or when used side coils must be replaced, the following equivalent Stucki side coil springs are available: RFE-41 outer side coil: (replaces B353) and RFE-41 inner side coil: (replaces B354).

## C. INSPECTION OF SIDE FRAME COLUMN WEAR PLATES

Column wear plates must be inspected for wear or cracks and replaced as required in accordance with conventional practices.

## D. ASSEMBLY INTO TRUCK

If the conditions described in the preceding instructions A, B, and C for retrofit application have been met, the RFE-41 elements may be assembled into the truck.

Procedure for installation of RFE-41 wedges is virtually identical to that of conventional wedges.

1. The urethane pad should arrive assembled onto the slope face of the wedge casting. If it has become disengaged in shipping, refer to paragraph IV C.
2. Insert the wedge assembly upward into pocket urethane pad facing truck bolster pocket slope. If the pad does not pass into the wedge cavity easily, check the bottom corners of the pocket for upset metal "flash" resulting from truck spring action or wear on the bottom of the bolster.
3. Wedge retaining pins may be used if desired but are not required. They should be removed after the truck is completely assembled, before the car is released for service.
4. Holding the wedge in place, insert the proper side coil springs, 11.B.1 top first, making sure of proper seating on the bottom of the wedge. If retaining pins are not available, continue to lift spring and wedge upward to allow the bottom of the spring to pass over the retaining lugs on the side frame seat for proper positioning.

5. After all wedges and truck springs have been installed, lower the bolster onto the springs and then lower car body onto truck. Visually check the wedges for proper positioning in bolster pocket. Wedges should be reasonably well seated against bolster slope and column wear plates, and side coil springs should be checked that they are seated properly on the wedges and are not partially seated against the bolster surface.

## III. SERVICE INSPECTION OF RFE-41

### A. TRAINYARD INSPECTION

1. Check wear limit indicators (Fig. 1). The wedge must be replaced when either witness groove has been worn away and is no longer visible.
2. Check the top edge of the resilient pad for flush seating against the wedge surface and bolster pocket slope.
3. The top edge of a new resilient pad is 5/8" thick. Pads will assume a slight amount of permanent set in normal service. If the top edge of the pad is less than 3/8" thick, either pad or entire assembly replacement is advised.
4. Broken wedge springs must be replaced. Springs displaced from properly engaged position, top or bottom, must be corrected as soon as possible.
5. Broken, cracked, or loose column guide wear plates must be repaired or replaced as required.

### B. SHOP INSPECTION

Inspection of RFE-41s when a car is shopped, with trucks disassembled, must follow guidelines outlined above (for trainyard inspection) plus:

1. Wearing faces of resilient pads should be checked. If the pad is 3/8" thick or less, the pad must be replaced.
2. Free height of wedge springs should be checked in accordance with requirements noted in paragraph II.B.1 above.

## IV. REPLACEMENT OF RFE-41 COMPONENTS

- A. Resilient pads and/or castings must be replaced in pairs. If one casting or one pad requires replacement, both pads and/or both castings on a given bolster end should be replaced. It is strongly recommended to replace by the truck set, though.
- B. Removal and replacement of any of the components of the RFE-41 system is accomplished in the same manner as a conventional S-2-HD snubbing system.
- C. It is possible to replace either the resilient pad or the iron wedge of an RFE-41 assembly. The pad can be pried free from the wedge with a screwdriver. The pad and wedge are reassembled by aligning the interlocking post on the waffled face of the pad with the tapered hole on the sloped face of the wedge and driving them together by impacting the pad surface with a mallet.