

STUCKI RFE-16 RESILIENT FRICTION ELEMENT INSTALLATION INSTRUCTIONS

The Stucki RFE-16 resilient friction element is a column friction snubbing assembly that replaces the Standard Car Truck Company 678-C or 787-C cast iron friction wedges on 6x11 and 6-1/2x12 Barber trucks.

The purpose of the RFE-16 is to reduce the wear that normally occurs on the slope surfaces and sidewalls of the friction wedge pockets in the truck bolster. Friction snubbing forces are the same as that of the S-2 system, which the RFE-16 replaces.

I. NOMENCLATURE AND PARTS DESCRIPTION

The RFE-16 assembly (Fig. 1) consists of an austempered ductile iron wedge and a resilient urethane pad affixed to the sloped face of the wedge. The two pieces lock together by means of a "waffle" arrangement at the interface and an interlocking post on the pad which is retained by a tapered hole on the sloped face of the wedge. Along each edge of the vertical (or wearing) face of the wedge are witness grooves to indicate the allowable wear limit. The sloped face of the iron wedge has two resilient pad wear indicators that will contact the bolster slope surface if the pad face wears to condemnable limit. The bottom of the wedge is made in two styles: one for a single side coil arrangement and one for a double side coil arrangement. The nomenclature "RFE-16 single coil" or "RFE-16 double coil" is indicated on the bottom of the wedge casting.

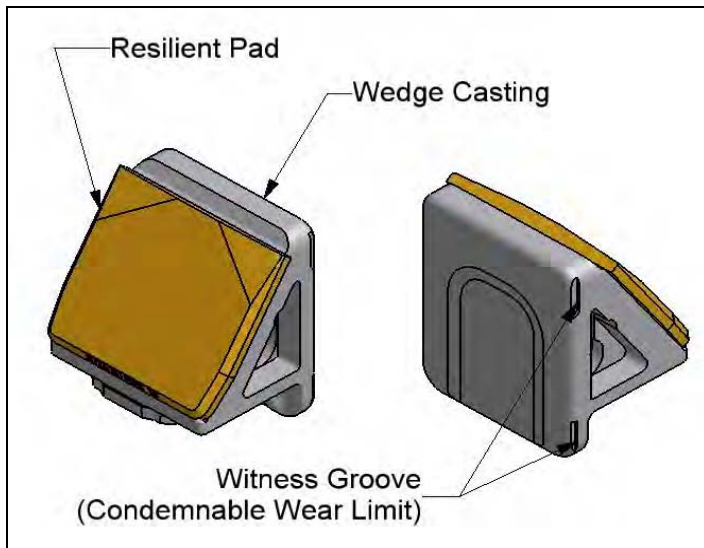

Figure 1

Other parts of the RFE-16 system include one or two load carrying springs and a hardened wear plate attached to the side frame column. These components are identical to the side coil springs B432 and B433, and column wear plates used in conventional variable column friction system. In the case of retrofit applications, side springs and column wear plates need not be replaced if in satisfactory condition.

II. INSTALLATION INSTRUCTIONS

The following instructions, A, B and C, apply generally to retrofit applications. For new car applications, proceed with Instruction D, Assembly Into Truck.

A. TRUCK BOLSTER PREPARATION

Although no bolster modification is required for RFE-16 installation, it is essential that wedge pocket conditions be inspected for compliance with the following requirements:

1. POCKET SLOPE SURFACE WEAR

If a bolster pocket slope exhibits more than 1/8" wear (Fig. 2) when referred to a Barber No. 6 (or SK-1689-6) bolster pocket slope gage, the surface must be restored either by rebuilding with weld or by addition of a 1/4" thick slope wear plate, in accordance with conventional practice.

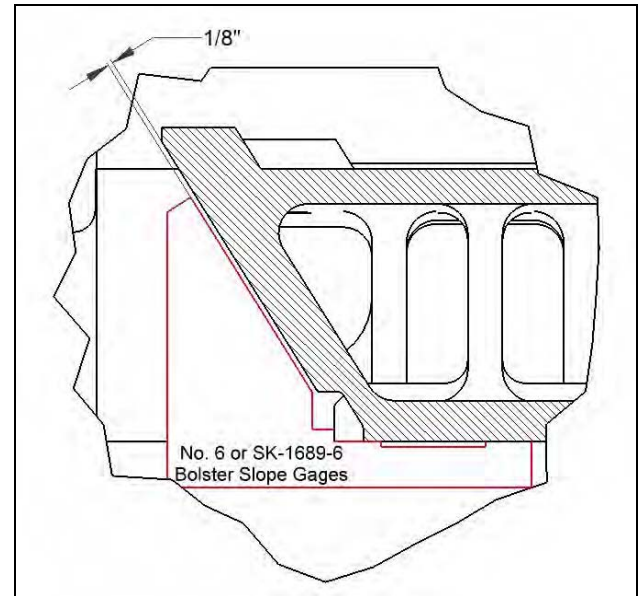

Figure 2

If the slope surface has been rebuilt, the welded area must be ground smooth and flat. This must include removal of weld spatter in corners and on sidewalls of the pocket within 3/4" of corners (see Fig. 3).

If new slope surface wear plates are applied, all welds, including any center plug-welds, must be ground flush with the wear plate surface. If pocket slopes have previously been fitted with wear plates, they should be inspected and replaced, if necessary, in accordance with Interchange Rule 47. If slope wear plates are of the shorter retrofit style (4" long), the bottom edge must be chamfered by grinding to approximately 1/4" wide by 1/16" deep.

IMPORTANT: In all cases, the bolster surfaces that will be in contact with the urethane pads of the RFE-16 wedges must be reasonably smooth and free of projections that may gouge the urethane pad surface. In no case should the RFE-16s be installed unless rebuilt bolster surfaces have been ground smooth as noted above. Bolster pocket slopes must not be lubricated.

2. POCKET SIDEWALL WEAR

In most cases, the outboard vertical wall or side of the wedge pocket in the truck bolster wears more rapidly than the inboard sidewall. If the pocket width has increased to greater than 6", the sidewall showing the greatest wear should be restored to the "as new" condition by rebuilding with weld in accordance with conventional practice. Only the area within 3/4" of the sidewalls need be ground smooth (see Fig. 3).

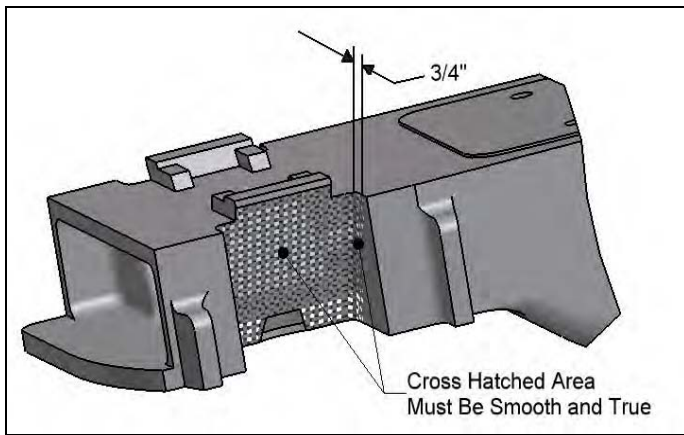

Figure 3

B. INSPECTION OF FRICTION WEDGE SPRINGS

1. If existing side coil springs are to be re-applied with the RFE-16 assembly, they should be checked for sufficient free height to insure proper loading of the wedges. Minimum acceptable free heights are 10-11/16" for B432 outer side coil, and 11" for B433 inner side coil.
2. When RFE-16 applications are made to new cars or when used side coils must be replaced, the following equivalent A. Stucki Company side coil springs are available: RFE-16 outer side coil (replaces B432) and RFE-16 inner side coil (replaces B433).
3. In the case of many 70-ton cars, only the outer side coil is used. The proper RFE-16 wedge configuration must be specified, depending on whether the application requires single or double side coils. The spring seat on each RFE-16 casting has inscribed either RFE-16 single coil or RFE-16 double coil.
4. If RFE-16s are to be installed in trucks with D-3 spring groups, then A. Stucki Company should be contacted for further instructions.

C. INSPECTION OF SIDE FRAME COLUMN WEAR PLATES

Column wear plates must be inspected for wear or cracks and replaced as required in accordance with standard practices.

D. ASSEMBLY INTO TRUCK

If the conditions described in the preceding instructions A, B, and C for retrofit application have been met, the RFE-16 elements may be assembled into the truck.

Procedure for installation of RFE-16 wedges is virtually identical to that of conventional wedges:

1. The urethane pad should arrive assembled onto the slope face of the wedge casting. If it has become disengaged in shipping, refer to paragraph IV.C.
2. Insert the wedge assembly upward into the pocket with the urethane pad facing the truck bolster pocket slope. If the pad does not pass into the wedge cavity easily, check the bottom corners of the pocket for upset metal "flash" resulting from truck spring action or wear on the bottom of the bolster.
3. Wedge retaining pins may be used if desired, but are not required, and they should be removed after the truck is completely assembled before the car is released for service.

4. Holding the wedge in place, insert the proper side coil springs (see B.2 and B.3), top first, making sure of proper seating on the bottom of the wedge. If retaining pins are not available, continue to lift the spring and wedge upward to allow the bottom of the spring to pass over the retaining lugs on the side frame seat for proper positioning.

5. After all wedges and truck springs have been installed, lower the car body onto the truck, then visually check the wedges for proper positioning in the bolster pocket. Wedges should be reasonably well seated against the bolster slope and column wear plates, and side coil springs should be checked that they are seated properly on the wedges and are not partially seated against the bolster surface.

III. SERVICE INSPECTION OF RFE-16s

A. TRAINYARD INSPECTION

1. Check the wear limit indicators (Fig. 1). The wedge must be replaced when the wear limit indicators have been worn away and are no longer visible.
2. Check the top edge of the resilient pad for flush seating against the wedge surface and bolster pocket slope.
3. The top edge of a new resilient pad is 5/8" thick. The pad will assume a slight amount of permanent set in normal service, and is also designed to accommodate 1/4" wear before the pad wear limit indicators on the wedge make contact with the bolster slope. If the top edge of the pad is less than 3/8" thick, repair track inspection and pad replacement are advised.
4. Broken wedge springs must be replaced. Springs displaced from their properly engaged position, top or bottom, must be corrected as soon as possible.
5. Broken, cracked, or loose column guide wear plates must be repaired or replaced as required.

B. SHOP INSPECTION

Inspection of RFE-16s when a car is shopped with trucks disassembled must follow guidelines outlined above (for trainyard inspection) plus:

1. Wearing faces of resilient pads should be checked. If the wear limit indicators are exposed, the pad must be replaced.
2. Free height of wedge springs should be checked in accordance with requirements noted in paragraph II.B.1 above.

IV. REPLACEMENT OF RFE-16 COMPONENTS

- A. Resilient pads and/or castings must be replaced in pairs. If one casting or one pad requires replacement, both pads and/or both castings on a given bolster end should be replaced.
- B. Removal and replacement of any of the components of the RFE-16 system are accomplished in the same manner as a conventional S-2 snubbing system.
- C. It is possible to replace either the resilient pad or the iron wedge of an RFE-16 assembly. The pad can be pried free from the wedge with a screwdriver. The pad and wedge are reassembled by aligning the interlocking post on the waffled face of the pad with the tapered hole on the sloped face of the wedge and driving them together by impacting the pad surface with a mallet.